

050-0107  
Two Rotor Latch  
With Coaxial Trip



This two rotor latch is a sub-platform to the TriMark proven 050-0100 series latch and is designed for medium to heavy-duty applications for on or off highway entrance doors, compartments and access panels. It features a coaxial trip mechanism for applications where it is desirable to provide additional support to the trip lever and is FMVSS 206 compliant.

**DESIGNED FOR:**

- Medium to heavy weight doors for on or off-highway vehicle applications
- Door thicknesses of 1-7/8" or greater (47.6mm)
- Door weights of 50-200 lbs. (23-91 kg)
- Door seal pressures of 50-150 lbs. (23-68 kg) (suggested for best results)
- Applications where it is desirable to provide additional support to the trip lever



[www.trimarkcorp.com](http://www.trimarkcorp.com)

**TriMark Corporation**  
500 Bailey Avenue  
P.O. Box 350  
New Hampton, Iowa 50659  
United States  
Tel: 641-394-3188  
Fax: 641-394-2392  
1-800-447-0343  
[www.trimarkcorp.com](http://www.trimarkcorp.com)

**TriMark Europe**  
Cedar Court  
Walker Road  
Bardon Hill  
Coalville LE67 1TU  
United Kingdom  
Tel: +44(0)1530 512460  
Fax: +44(0)1530 512461  
[www.trimarkeu.com](http://www.trimarkeu.com)

**AVAILABLE:**

- In left or right hand configurations (right hand shown)
- With (4) 1/4-20 UNC or M6 X 1 threaded axles or .286" (7.3mm) diameter "thru" axles
- With trip lever options (please inquire)
- With a torsion return spring

**FINISH:**

- Zinc plated, clear chromate steel components

**MATERIAL:**

- Internal latch components: heat treated, smooth edge stamped steel
- Case halves: high strength steel
- Springs: non-corrosive stainless steel

**INSTALLATION:**

- (4) 1/4-20 UNC grade 5 or M6 X 1 class 8.8 or better fasteners are required (not included).
- Tighten to the fastener manufacturers' recommended torque value, however, do not exceed 120 in-lbs (13.3 N-m)
- Fastener mounting holes diameter should not exceed .281" (7.1mm)

**INTERNAL LUBRICATION:**

- Oven-cured dry lubricant is applied at factory on all critical moving parts

**STRIKER INSTALLATION**

- Install striker bolt in door frame
- Close door carefully and check for interference between head of striker bolt and latch components
- Add or remove shims under striker bolt washer as required (outside diameter of shim should be larger than outside diameter of striker bolt washer)
- Adjust striker bolt vertically so door is not guided upward or downward while being closed
- CHECK TO DETERMINE THAT BOTH SECONDARY AND PRIMARY LATCHING POSITIONS ARE USABLE
- Door should be latched but not "closed" in secondary position with respect to adjacent surfaces in primary position
- If both primary and secondary positions are not evident, readjust striker bolt
- After installation, check door alignment and door seal pressures

**Individual part dimensions are for reference only. Refer to individual part drawings for complete dimensions, specifications, and installation procedures. Engineering assistance and application drawings are available.**

Applications of this latch may fall within the requirements of FMVSS 206 and SAE J839 safety standards. These safety related requirements are dependent on door application, e.g. front and rear hinged doors, sliding doors, or hinged upward swinging doors. The entire door hardware system must be included in the design/analysis process: latch, handle, lock mechanism, cables/rods/linkages, fasteners, hinges, etc. This ensures compatibility of all components within the hardware system. If FMVSS 206 is a requirement, then all of the components within the door system must comply with strength, inertia and locking requirements as specified within the Standard. Note that this product complies with FMVSS 206 when tested with approved TriMark Striker Bolts in accordance with SAE J839 and that this product meets FMVSS 206 load requirements and may be used in FMVSS 206 applications pending TriMark application approval.

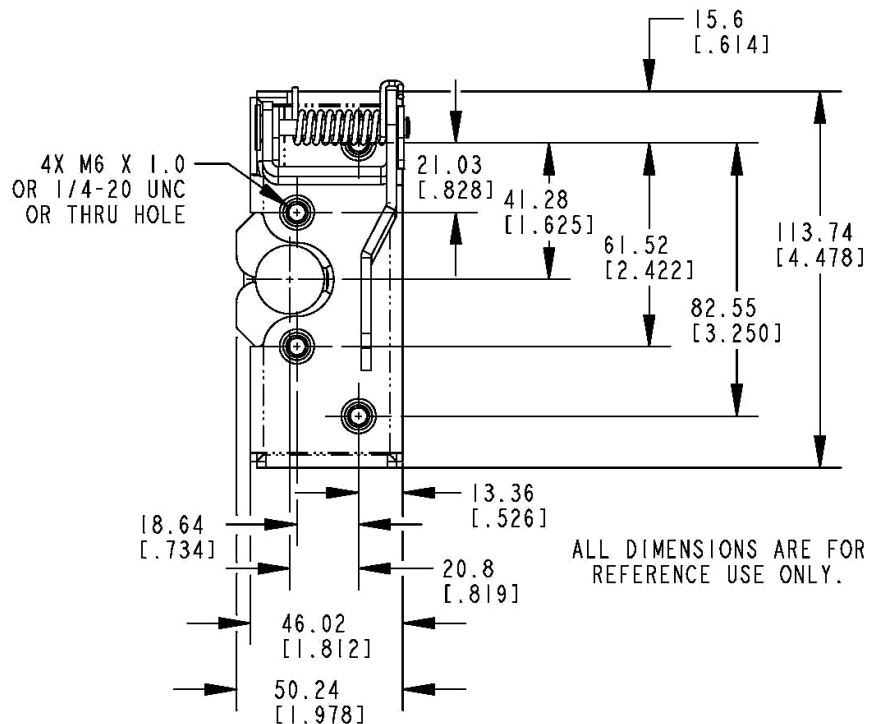
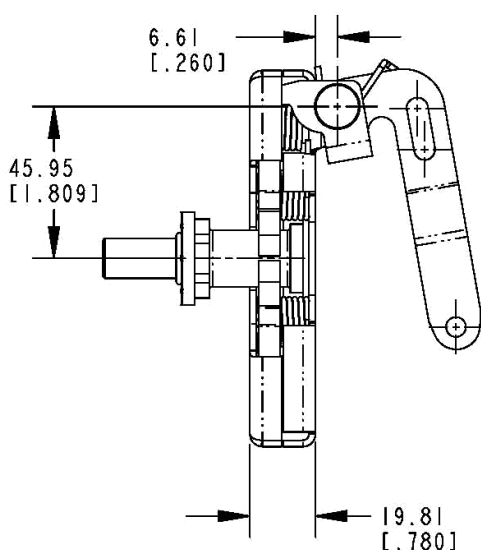

ALL DIMENSIONS ARE FOR REFERENCE USE ONLY.

For more information visit  
[www.trimarkcorp.com](http://www.trimarkcorp.com)